

OFFSITE MODULAR STEELWORK

DESIGN ADVICE



OFFSITE MODULAR STEELWORK

DESIGN ADVICE



SCI (the Steel Construction Institute) has been a trusted, independent source of information and engineering expertise globally for over 30 years, and is one of the leading, independent providers of technical expertise and disseminator of best practice to the steel construction sector.

We support everyone involved in steel construction; from manufacturers, consulting and design engineers, architects, product developers to industry groups.

Our service spans the following areas:

Membership

Individual & corporate membership

Advice

Members advisory service

Information

Publications

Education

Events & training

Consultancy

Development

Product development

Engineering support

Sustainability

Assessment

SCI Assessment

Specification

Websites

Engineering software

© 2020 The Steel Construction Institute
and BCSA.

Publication Number: **SCI P430**

ISBN 13: 978-1-85942-244-1

British Library Cataloguing-in-Publication Data.

A catalogue record for this book is available
from the British Library.

Published by:

SCI, Silwood Park, Ascot,
Berkshire. SL5 7QN UK

T: +44 (0)1344 636525

F: +44 (0)1344 636570

E: reception@steel-sci.com

www.steel-sci.com

To report any errors, contact:

publications@steel-sci.com

Apart from any fair dealing for the purposes of research or private study or criticism or review, as permitted under the Copyright Designs and Patents Act, 1988, this publication may not be reproduced, stored or transmitted, in any form or by any means, without the prior permission in writing of the publishers, or in the case of reprographic reproduction only in accordance with the terms of the licences issued by the UK Copyright Licensing Agency, or in accordance with the terms of licences issued by the appropriate Reproduction Rights Organisation outside the UK.

Enquiries concerning reproduction outside the terms stated here should be sent to the publishers, The Steel Construction Institute, at the address given on the title page.

Although care has been taken to ensure, to the best of our knowledge, that all data and information contained herein are accurate to the extent that they relate to either matters of fact or accepted practice or matters of opinion at the time of publication, The Steel Construction Institute, the authors and the reviewers assume no responsibility for any errors in or misinterpretations of such data and/or information or any loss or damage arising from or related to their use.

Publications supplied to the Members of the Institute at a discount are not for resale by them.

OFFSITE MODULAR STEELWORK

DESIGN ADVICE

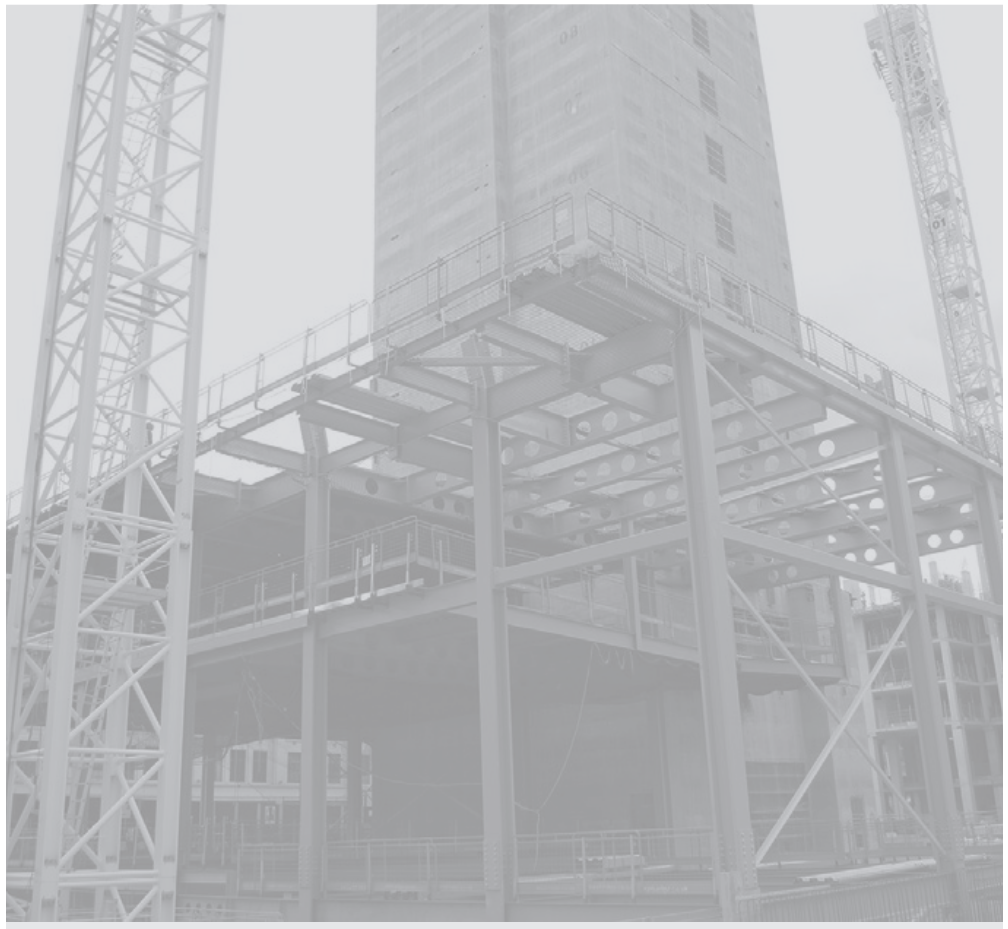



FOREWORD

With support from Innovate UK, the opportunities for increased modularisation and integration in multi-storey steel construction have been examined and a number of beneficial technical solutions identified.

The primary benefits include a shorter construction period, removal of wet trades, earlier weatherproof envelope and higher quality construction. Most of these benefits are facilitated by moving work offsite. Offsite prefabrication and assembly leads to fewer deliveries to site, less working at height and less site waste.

This guide presents design guidance for typical solutions which may be exploited immediately, recognising that the particular context of a structure (spans, loading, service provision etc) will lead to a standardised, but nevertheless unique solution.

A companion guide^[4] designed to alert clients to the benefits of increased offsite construction presents the solutions at a conceptual level.



CONTENTS

FOREWORD	iii
SUMMARY	vii
1 OPPORTUNITIES FOR STEEL CONSTRUCTION	1
1.1 Faster, higher quality construction	1
1.2 Government initiatives	1
2 STEEL BUILDING CORES	3
2.1 Structural concept	4
2.2 Benefits of steel-composite cores	5
2.3 Design guidance	6
3 SINGLE STOREY STEEL COLUMNS	17
3.1 Concrete filled hollow section columns	17
3.2 Concrete encased steel sections	17
3.3 Concrete filled tubular columns with steel cores	20
3.4 Single storey columns	21
4 DRY FLOOR PLATES	23
4.1 Floor plate design with panels	23
4.2 Composite floor panels	25
4.3 Cross laminated timber (CLT) floor panels	30
4.4 Light gauge floor cassettes	33
4.5 Façades and roof panels	37
5 INTEGRATED SERVICES	42
REFERENCES	43



SUMMARY

With support from Innovate UK, a collaborative project was established to investigate the opportunities to increase construction sector productivity by the use of offsite steel modules. This guide presents design information for the technical solutions identified during the project. The advantages of an integrated, offsite solution are presented in Section 1.

Section 2 describes the design of steel concrete composite cores, which in some circumstances offer benefits of speed, accuracy, strength and stiffness, compared to a concrete core.

Section 3 describes the design of single storey columns, with concrete encasement if desired, which are highly suited for offsite manufacturing using robotic fabrication techniques.

Section 4 describes “dry” floor plates, erected as individual panels, which have the significant advantage of removing a number of processes from site, including the casting of concrete.

Some proposed solutions may have higher initial costs than the orthodox alternative, or may have other disadvantages such as increased floor depth. In all cases, a holistic view of the proposed solution must be taken, valuing the benefits whilst recognising any disadvantages of a proposed solution.

The project team recognised that further advantages are possible by integrating services into the structural solution, but that for various reasons, those advantages are not always realised. Section 5 describes the main reasons which militate against the regular integration of services and simply points out the necessary project characteristics if benefits from service integration are to be gained.

The project partners were:

The British Constructional Steelwork Association Ltd (BCSA)

The Steel Construction Institute (SCI)

Severfield

WSP

Trimble

Valuable guidance was also provided by:

William Hare Group Ltd

Caunton Engineering Ltd

Billington Structures Ltd

BSRIA

British Steel

SPIE



OPPORTUNITIES FOR STEEL CONSTRUCTION

This publication presents design guidance for a number of offsite solutions, which may be adopted to make the construction of multi-storey buildings faster, safer and to a higher quality. It is readily accepted that some solutions presented in this guide have a higher initial cost than the traditional alternatives. However, savings in construction time can more than offset the cost penalty. In some cases offsite solutions are valued as they reduce deliveries to site, reduce working at height and allow earlier access to following trades.

Increasing the proportion of work completed offsite generally requires single construction organisations to take responsibility for multi-material components that would otherwise often be completed by several different trades on site. Steelwork contractors are generally used to coordinating other sub-contractors, so this increased responsibility may be a natural progression.

1.1 Faster, higher quality construction

Moving activities offsite shortens the construction period onsite. This may be the key advantage of increase offsite preconstruction. A largely offsite construction process has the advantages of:

- Enhanced quality, due to factory control;
- Reduced deliveries to site;
- Reduced manpower on site;
- Positive impact on safety;
- Earlier dry envelope, and early access for the following trades;
- Reduced “wet” trades (such as placing concrete);
- Reduced interfaces between components;
- Societal benefits arising from a factory-based workforce.

1.2 Government initiatives

Recent Government initiatives^{[2], [3]} have emphasised the advantages that flow from increased offsite manufacture. In 2017, as a manifestation of Government commitment, the Chancellor of the Exchequer announced that five central government departments would adopt a presumption in favour of offsite construction, leveraging their buying power to support the modernisation of the construction sector.

Subsequently, the government set out a 'new approach' to building, to be adopted across all government departments where it presents value for money. They called this a platform approach to design for manufacture and assembly (P-DfMA).

A platform approach to DfMA (P-DfMA) is the use of a set of digitally designed components across multiple types of built asset that are then used wherever possible, minimising the need to design bespoke components for different types of asset.

By taking a consistent approach and using standardised and inter operable components across a range of different buildings, the government hopes to encourage the creation of a new market for manufacturing in construction and to take advantage of economies and efficiencies of scale.

The Treasury believes that adopting this approach can boost productivity whilst also reducing waste by up to 90%.



STEEL BUILDING CORES

Many multi-storey steel buildings are stabilised by concrete cores, which are slip-formed or jump-formed in advance of the erection of the floor steelwork.

In some circumstances, compared to a traditional concrete core, a steel concrete composite (SC) core can offer significant advantages of faster construction, thinner core walls, compatible erection tolerances with the surrounding floor steelwork and straightforward connection details. A SC core is stiffer and stronger than a concrete core of the same thickness, meaning that the steel core might be smaller overall, or for a large structure, fewer cores may be needed. The reduced weight of a SC core has a further positive benefit in smaller foundation loads than the traditional equivalent.

Although a UK view is that the initial cost of a steel core is significantly more expensive than a traditional concrete core, recent experience (2019) in North America with the construction of the Rainier Square building, Seattle, suggests that changing from a traditional concrete core to a SC core delivered considerable benefits.



Figure 2.1 – Rainier Square, Seattle

The 58 storey Rainier Square building, shown in Figure 2.1, was topped out in 10 months with a SC core, compared to the 18 month period anticipated for a traditional concrete core^[4]. The choice of a SC core is reported to have saved 2% in cost^[5]. Reports also note the advantage of compatible tolerances with the floor steelwork.

In the USA this core system is known as ‘Speedcore’^[6] and although it is presented as an innovative system, the concept has been used in the UK since 2005, when it was known as ‘Corefast’.

2.1 Structural concept

SC cores are constructed from prefabricated steel panels. Each panel has external steel plates, which acts as permanent formwork for the concrete fill, which is poured on site. The two steel walls are held in position by bars between the steel plate, welded (or bolted) at intervals. To provide composite action, shear studs are welded to the inside of the plates. Usually, columns (which may be composite box sections) are erected first, with panels then erected between columns and the joints completed. As an alternative, Figure 2.2 shows a prefabricated joint between panels.

Panels are erected in the empty condition and joined together to form the core. In American practice, the joints are welded (possibly because of seismic resistance). Alternatively joints can be bolted temporarily with the final continuity achieved using preassembled dowels placed across the joints inside the panels before the concrete is poured.



Figure 2.2 –
Proprietary steel-
composite core
panel – joint
between panels

2.2 Benefits of steel-composite cores

The key benefits of a steel-composite core are:

- Speed of erection;
- High strength and stiffness;
- Lighter weight;
- Accuracy;
- Minimal requirements for temporary works;
- Ease of making attachments;
- Quality.

2.3 Design guidance

Steps in completing the design of a core generally fall into three stages:

1. Analysis of the entire structure to determine the actions on the core. This is the same activity whatever the core construction.
2. A preliminary analysis of the core under the applied actions, based on an assumed wall thickness and form, including steel plate thickness. This analysis will produce an estimate of the design effects (forces and shears at critical sections in the core) which may be used to complete an initial verification of the assumed section.
3. Modelling and analysis of the (possibly refined) section, assessment of the building stiffness and verification of the core wall components.

2.3.1 Analysis of the structure

In a perfectly symmetric building, with a symmetric location of cores, it may be assumed that the floor plates transfer lateral forces to the cores; the forces on the cores may be determined from a simple analysis of the building as the forces are independent of core stiffness.

For the normal condition of an asymmetric structure, or cores of dissimilar form, lateral loads will not be equally shared between cores and the cores will be subject to torsional forces.

With a single core, the lateral and torsional forces can be determined by a simple analysis. For more complex situations it will be necessary to model the entire building with appropriate lateral and torsional stiffness of the cores.

2.3.2 Openings in cores

Cores will inevitably have openings to allow access to lifts, stairs and services within the core. The effect of the openings on the structural behaviour of the core depends on the dimensions of the openings compared to the dimensions of the core. Where the core has openings on each floor only on one face, as shown in Figure 2.3, and the elements

that remain between the openings are shallow and flexible, the core will behave as an “open” structural member – effectively a ‘lipped C section’ as shown in Figure 2.4.

Left:
Figure 2.3 – Core
with large openings
in one face only

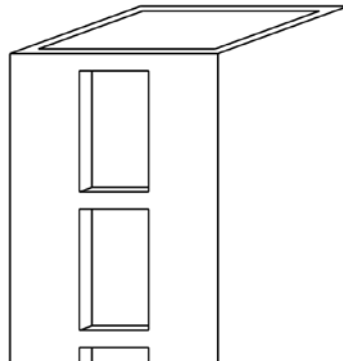

Right:
Figure 2.4 –
Sectional plan of
core with openings
in one face only

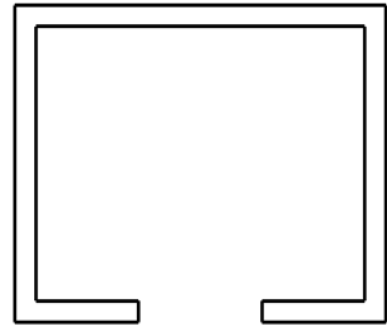

If there are openings on opposite faces of the core on each floor, such as shown in Figure 2.5, the core will act more like two independent members in resisting lateral forces, as shown in Figure 2.6. In resisting torsional forces, the torsional stiffness is greater than the simple sum of two open sections, since the two elements are constrained by the floor plates to twist as a unit, rather than independently.

Left:
Figure 2.5 – Core
with openings in
opposite faces

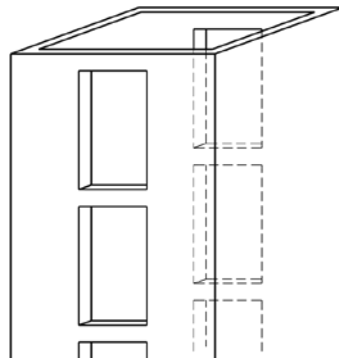

Right:
Figure 2.6 –
Sectional plan of
core with openings
in opposite faces

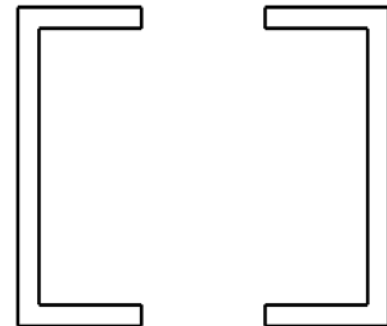

Since openings have such a major effect on the stiffness of a core, it is very important to model them and the link elements correctly.

In most arrangements, the link elements are relatively deep, typically around 20% of the storey height. The links should be modelled, with rigid connections to the core walls, so that the correct stiffness and deflection performance is determined.

If the link elements are unusually shallow, they offer very little structurally to the core, so they may be ignored when modelling the structure. If link elements are ignored in the model, they should be detailed with simple (nominally pinned) connections to the core walls.

If the link elements are deep (i.e. the opening height is significantly less than the floor-floor height) the behaviour of the core may be similar to that of a closed section, but this would have to be proven by appropriate modelling (see Section 2.3.4).

2.3.3 Initial sizing

Generally, the overall size of a core is determined by the space requirements for stairs, lifts, services etc. For very tall buildings, there may be more cores at lower levels, which are reduced in steps at higher levels in the building where lifts terminate. Larger forces are generally accommodated by increasing the resistance of the core walls (by thickening the walls) rather than increasing the number of cores.

At the most simple level, if there are rigid connections between the core walls, a bending moment applied to the core may be assumed to be carried by two opposing walls of the core. The normal forces in the core walls are simply the applied moment divided by the lever arm between walls. This is conservative as it ignores the contribution from the “side” walls. This simple approach cannot be used if the links between openings are flexible.

Table 2.1 presents approximate compression resistances per metre length of SC panels which may be used to establish a preliminary size of wall. The compression resistance is likely to be critical, rather than the tensile resistance. The compression resistances are based on a typical storey height, but do not vary much as the storey height is modified.

Table 2.1 – Indicative resistance to axial compression of steel-composite panels

Overall width (mm) (concrete core + steel plates)	Steel plates (mm)	Compression resistance (kN/m)
200	8	7700
300	10	10500
300	20	15000

2.3.4 Preliminary analysis

Preliminary analysis may be completed by modelling the core wall using 2-dimensional finite elements based on an equivalent section in either steel or concrete.

Table 2.2 provides equivalent steel thicknesses which may be used to model a core.

Table 2.2 – Equivalent steel thickness for preliminary analysis

Concrete width (mm)	Steel plates (mm)	Equivalent steel plate thickness (mm)
200	8	31
200	12	39
300	10	42.5
300	15	52.5

This simple transformation into an equivalent steel section will allow the overall properties of the core to be readily established. From this analysis, the normal forces at critical cross sections (tension and compression) may be established and initial verification of the selected wall panel dimensions verified. A more precise transformed section will be needed for detailed design, as discussed in Section 2.3.5.

2.3.5 Detailed analysis

Finite element analysis should normally be used for detailed analysis and design of the core (indeed this may form part of a model for the whole building frame). Linear or non-linear approaches may be adopted. The effects of deformations of the core and the different material properties must all be modelled accurately.

Second order effects must be taken into account where they have a significant effect on the overall stability of a structure and where they have a significant effect on the design actions at the Ultimate Limit State (ULS).

Detailed guidance on the geometric and material properties to be used in a finite element analysis is given in SCI publication P414^[7]. Shell elements of equivalent homogeneous properties are recommended, instead of layered elements representing the individual steel and concrete elements of the wall.

Typical equivalent properties are presented in Table 2.3.

Panel details			Equivalent material properties		
Concrete (mm)	Steel plates (mm)	Thickness (mm)	E (N/mm ²)	Poisson's ratio ν	Density (kg/m ³)
200	8	294	21600	0.226	2060
200	12	314	25400	0.235	2129
300	10	428	20300	0.222	2049
300	15	457	23500	0.231	2091

Table 2.3 –
Thickness and
material properties
of equivalent steel
composite panels

In Table 2.3, the concrete grade is C32/40; the steel is S355.

The element type should be one that implements the 'Mindlin-Reissner' formulation with 8 degrees of freedom; 3 translations, 3 rotations and 2 shear deformations. For each element in the structure the appropriate stiffness matrix should be determined for use in the global analysis. The opportunity to define this matrix is usually allowed by conventional software packages.

2.3.6 Verification

SCI Publication P414 gives detailed guidance on the verification of steel concrete composite panels.

P414 covers the following verifications:

- Design of members in tension;
- Design of members in compression;
- Shear connection between steel and concrete;
- Bending resistance;
- Out-of-plane shear resistance;
- Resistance under combined actions.

Out-of-plane bending is not generally relevant for core walls.

In-plane bending of composite core walls can be verified using a similar process to that usually applied to concrete core walls. The steel plates act as reinforcement, with appropriate detailing of the connection between the plates to ensure that local buckling does not limit the compression resistance of the steel plates. Local buckling is prevented by limiting the spacing of the stud/tie bars that connect the plates.

To avoid plate buckling, the limitations given in Table 2.4 must be respected.

Table 2.4 – Limits to stud/tie bar spacing

Steel grade	S275	S355	S460
Maximum s/t_{pc}	34	30	26

where:

s is the length between points of out-of-plane restraint to the plate provided by a stud or a tie bar;

t_{pc} is the thickness of the steel plate in compression.

In very simple cases, it may be reasonable to assume applied actions act in the two orthogonal axes of the core and simplify the verification of the cross section.

More generally, design effects (shear, bending and axial forces) can be established at convenient cross sections (generally the floor levels) and the core cross section verified at each level. Some commercially available software allows the definition of general cross sections with user-defined material properties. The entire cross section may be modelled and verified using such software which are usually based on a strain compatibility design method.

Buckling verifications are presented in P414.

2.3.7 Base connections

Panels may be connected to the foundation in a number of ways:

- Starter bars projecting from a traditional reinforced concrete foundation (the common approach)
- Holding down bolts
- Panels cast into the foundation

Normally a small gap (typically 30 mm) is left under the panels to accommodate deviations in the foundation height. The gap is sealed with concrete before the panels are filled. Holding down bolts are used to provide temporary stability. A typical detail is shown in Figure 2.7.

In many cases, the compression forces may be sufficiently low to verify the connection resistance considering the concrete resistance alone.

In tension, the starter bars must be long enough to ensure transfer of force between the shear studs on the plate faces, plus a lap length.



Figure 2.7 – Base detail with packs and holding down bolts

2.3.8 Connections between panels

American practice is to fully weld the horizontal and vertical joints between panels. A bent steel plate is attached to one panel (the lower panel at horizontal joints), which helps locate the upper panels and acts as a backing strip for the weld which is completed from the outside, as shown in Figure 2.8.

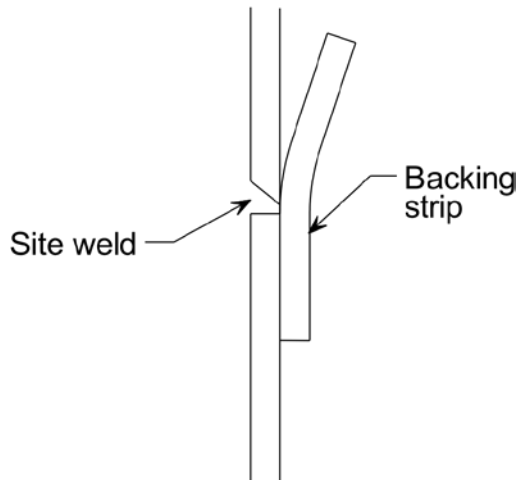

Figure 2.8 – Welded detail between panels

Bolted details may also be employed with internal cover plates and preloaded assemblies or blind bolts.

In many cases, the preferred method of connection panels may be a combination of welding, bolting for temporary conditions and internal dowels within the concrete to connect panels in the permanent condition. In this approach, a pre-assembled matrix of steel dowel bars are located across the joint, prior to the concrete filling. The matrix of dowels, illustrated in Figure 2.9, needs careful detailing to avoid clashing with the shear studs on the plates. Local to the joint, the bars connecting the plates must be bolted, so that they can be withdrawn as the dowels are inserted and then re-installed.

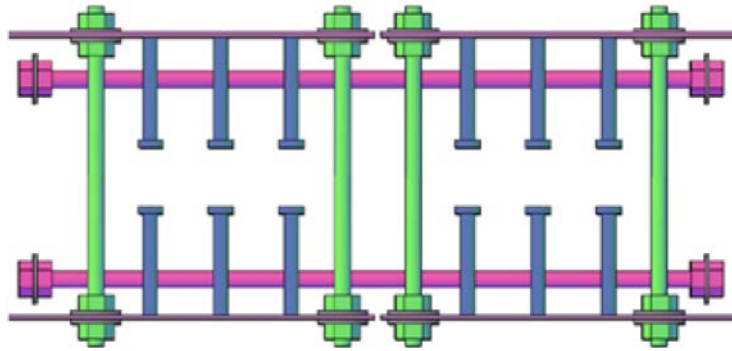

Figure 2.9 – Internal dowels across a panel joint

2.3.9 Connections to the core

One of the important advantages of a steel core is that connections to the core are straightforward, not requiring the large allowance for tolerances associated with a traditional concrete core. In addition, appropriate details can be added to the core walls offsite, facilitating the connection of the floor steelwork.

Figure 2.10 shows a fin plate connection for a floor beam, (with a supporting seating cleat) and angles welded to the core wall to support the floor decking. Excellent connections can be achieved between the floor slab and the core by adding shear studs to the supporting angles and providing appropriate reinforcement in the slab around the studs. This type of detail can be particularly useful when transferring forces from the floor diaphragm to the core, or when transferring tying forces to the core.



Figure 2.10 – Steel core with connections for the surrounding steelwork

Figure 2.11 shows a steel core with the surrounding steelwork and floor decking completed.

Fin plate details, as seen in Figure 2.10 and Figure 2.11 are typical for beam connections, which may be taken directly from tables of standardised details in SCI Publication P358^[8]. For beams with torsional loading, stub members may be fully welded to the core wall, with an end plate connection to the supported beam.



Figure 2.11 –
Completed core
and floor prior to
concreting

2.3.10 Fire resistance

Verification at elevated temperature involves the assessment of the (reduced) design actions, and calculation of the reduced buckling resistance. Guidance on the reduced value of actions and the reductions in strength for steel, concrete and shear studs are given in the fire Parts of the relevant Eurocodes. The temperature at which the resistance falls below the applied actions may be determined and fire protection specified to ensure this temperature is not exceeded at the required fire resistance period.

Alternatively, the time taken to reach this critical temperature may be determined, which must exceed the required period of fire resistance.

If the resistance is insufficient, fire protection will be required, which may be an intumescent coating or plasterboard.

Loaded and unloaded tests of Bi-steel panels^[9] (a proprietary SC system using bars friction welded between the steel plates) were completed with intumescent coating, with plasterboard or with a cementitious spray, which may be used as initial guidance for the necessary protection. Up-to-date guidance should be obtained from the protection material manufacturer.

2.3.11 Acoustic performance

Acoustic performance is likely to be important for cores generally, as they may contain lifts, stairs, landings and circulation spaces in addition to services.

Advice on acoustic detailing for steel framed buildings is given in SCI Publication P372^[10]. Typical details are likely to involve plasterboard mounted on steel studs or timber battens, with special attention paid to the detailing and sealing around junctions between floors and internal walls.



SINGLE STOREY STEEL COLUMNS

In typical multi-storey steel construction, columns are two or three storeys in height and generally fire protected with an intumescent coating, applied offsite. Steel beams are connected directly to the columns.

A P-DfMA approach (see Section 1.2) is facilitated using single storey standardised steel sections with simple connections supporting the floor construction. This form of construction is particularly suited to the 'dry floor' solutions discussed in Section 4.

Composite columns, which may be concrete filled hollow sections, partially encased open sections or fully encased open sections offer advantages at ambient temperature and at elevated temperatures. For very high axial loads, encased open sections (typically Universal Columns) are appropriate.

3.1 Concrete filled hollow section columns

The design of concrete filled hollow sections is covered by section 6.7 of BS EN 1994-1-1^[14]. Comprehensive guidance covering design at ambient and elevated temperatures is given in Non-contradictory complementary information (NCCI) resource PN006a-GB^[11]. Internal reinforcement will be required to reach a fire resistance period of 60 minutes.

Although Annex H of BS EN 1994-1-2^[15] provides a simple calculation model for the resistance of a concrete filled hollow section at elevated temperatures, the UK National Annex prohibits the use of this Annex in the UK. AD 376^[12] explains the background to the UK decision.

FIRESOFT software^[13] is available from Tata and may be used to verify concrete filled columns at ambient and elevated temperatures.

3.2 Concrete encased steel sections

Opportunities arising from offsite manufacture include partial or full encasing with concrete. This increases the resistance of the column significantly - so less material is needed compared to an uncased section. A second significant advantage is that the fire resistance of a partially or fully encased section is increased. The need for fire protection is substantially reduced or not required, reducing costs.

Full or partial concrete encasement is added over the exposed length of the column. Connection zones are left uncased, to facilitate connections to the floor beams. Uncased connection zones will need to be verified (see Section 3.2.3) and may need encasement or other protection for the fire condition.

3.2.1 Partially encased steel sections

In multi storey buildings, the relatively high axial loads mean that open sections (Universal Columns) are often the preferred profile.

Partial encasement involves casing concrete between the flanges, as shown in Figure 3.1. The concrete will be reinforced.

3.2.2 Fully encased steel sections

The cross section of a fully encased column is shown in Figure 3.2.

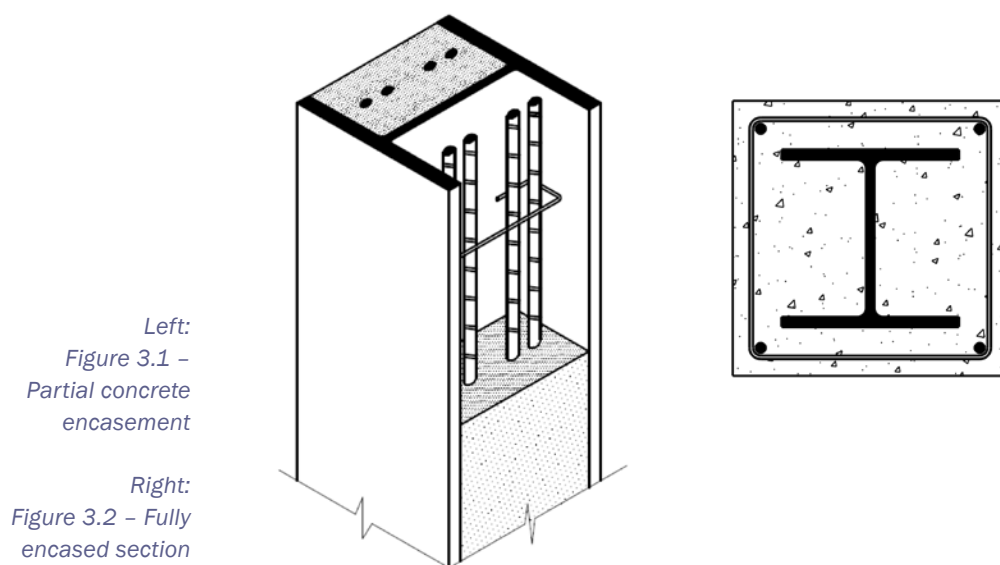

3.2.3 Design verification at ambient temperature

The design of composite columns is covered by BS EN 1994-1-1^[14]. The calculation of the fire resistance of composite columns is given in BS EN 1994-1-2^[15]. Comprehensive design guidance is also presented in Section 23 of the Steel Designers' Manual^[16].

The design resistance of partially and fully encased steel columns may be verified using freely available software from Centre Technique Industriel De La Construction Metallique (CTICM). 'A3C' software may be downloaded from <https://www.cticm.com/centre-de-ressources/> which verifies composite columns at ambient and elevated temperatures in accordance with EN 1994.

The increase in resistance for typical partially and fully encased concrete is illustrated in Table 3.1. The buckling length in each case was taken as 4 m.

Table 3.1 –
Indicative ultimate
buckling resistances
of bare steel,
partially encased and
fully encased steel
sections

Ultimate resistance (kN) and % increase on bare steel resistance					
Member (all S355)	Bare steel	Partially encased		Fully encased	
305 × 305 × 158	5220	6690	+28%	8700	+67%
356 × 406 × 287	10600	12800	+20%	14900	+41%
356 × 406 × 551	19700	21900	+11%	24200	+22%

In each case in Table 3.1, the quoted resistance is the minor axis buckling resistance. Fully encased sections have approximately 60 mm of concrete all around the section.

3.2.4 Verification at elevated temperature

The A3C software may be used to calculate the resistance of the partially or fully encased column in the fire condition.

For partially encased columns, Table 4.6 of BS EN 1994-1-2 specifies certain minimum dimensions, minimum areas of reinforcement and minimum web to flange thickness ratios which will meet stated periods of fire resistance with no further calculation. Requirements are related to load levels in the fire condition. Table 3.2 extracts the requirements for fire periods of 90 and 120 minutes, being the periods commonly required in multi-storey buildings. In each case, the web-to-flange thickness ratio $t_w/t_f > 0.5$.

Table 3.2 –
Minimum
requirements for
partially encased
steel sections

		Fire resistance period (minutes)	
		90	120
Load level $\eta_{fi,t} \leq 0.28$	minimum overall dimensions	300 mm	400 mm
	minimum axis distance of reinforcement	50 mm	70 mm
	minimum ration of reinforcement	3 %	4%
Load level $\eta_{fi,t} \leq 0.47$	minimum overall dimensions	400 mm	
	minimum axis distance of reinforcement	70 mm	
	minimum ration of reinforcement	4%	

The load level $\eta_{fi,t}$ is essentially the unfactored axial force divided by the resistance at ambient temperature. If a column was fully utilised at ambient temperature, with usual values of permanent at variable actions, the value of $\eta_{fi,t}$ is approximately 0.57. Therefore, to satisfy the requirements in Table 3.2 for a 'deemed to satisfy' solution giving a 90 minute fire resistance period, the utilization of the column would need to be limited to around 80% of its resistance.

For fully encased steel sections, Table 4.5 of BS EN 1994-1-2 specifies minimum concrete cover such that the encased column will meet stated periods of fire resistance with no further calculation. Table 3.3 presents the requirements.

Table 3.3 –
Minimum cover
requirements for
fully encased steel
sections

	Fire resistance period (minutes)				
	30	60	90	120	180
Minimum concrete cover (mm)	0	25	30	40	50

3.2.5 Connection zones

Connection zones must necessarily be left without casing until the floor elements are erected.

There is no buckling behaviour within a connection zone, so the design verification is the check of the cross sectional resistance under the design effects.

The same calculation must be completed if the connection zone is subject to elevated temperatures, with appropriate reduction factors for the reduced steel strength taken from BS EN 1993-1-2^[17].

If necessary, the connection zone may be encased on site.

3.3 Concrete filled tubular columns with steel cores

Concrete filled hollow sections with embedded steel cores, as shown in Figure 3.3 enable very high loads to be resisted, or the cross section of the column element to be reduced. These types of columns are known as Geilinger columns. The cross sectional area of a Geilinger column is typically 25% of that of an equivalent reinforced concrete column. A further advantage is that high fire resistance is achieved without fire protection.

Composite columns with embedded cores cannot be verified using the simplified method given in BS EN 1994-1-1, primarily due to the high residual stresses in the steel core.

Comprehensive guidance on the design of this type of member is available, including practical ways of introducing load to the column^[18].

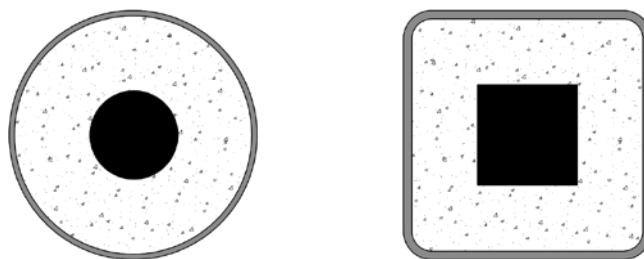

Figure 3.3 –
Concrete filled
hollow sections with
steel core

3.4 Single storey columns

Single storey columns facilitate a P-DfMA approach (see Section 1.2), and are easier to handle than longer elements. If cased with concrete, the reduced weight of shorter sections may be an advantage.

Shorter sections are more suited to robotic welding where material handling of long members is difficult.

Single storey columns may be designed as ‘discontinuous’ columns, where the floor beams are continuous over the column lines. If this solution is contemplated, care should be taken with the stability of the connection zone. Advisory Desk note 292^[19] recommends that the floor construction should be within the beam depth to provide restraint, not in the orthodox location above the top flange.

Single storey column connections may be arranged so that the floor panels (see Section 4) sit directly on top of the column, as shown in Figure 3.4(a). Alternatively, the column may be extended above the floor level with a simple splice detail and conventional connections to the floor beams, as shown in Figure 3.4(b).

In both arrangements, the key design verification for the splice is likely to be the tension resistance of the connection due to tying forces. Vertical tying is required for Class 2b buildings, which includes offices over four storeys.

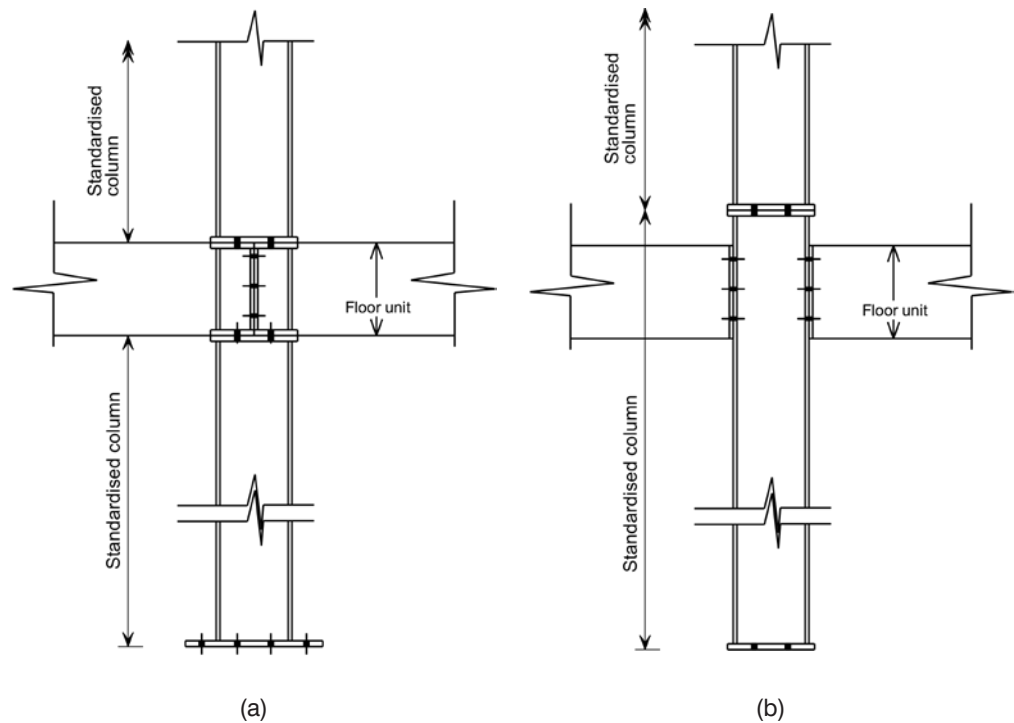

Figure 3.4 - Single storey column arrangements



HALLE

HALLE

DRY FLOOR PLATES

Floors in multi-storey buildings are typically composite slabs, comprising profiled steel sheet and in-situ concrete. The supporting beams are generally composite, with (in typical UK practice) shear studs welded through the steel sheet to the top of the steel beam.

This floor solution involves laying out and fixing the decking sheets, adding edge trim, completing the through-deck welding of shear studs, laying reinforcement and pouring the concrete.

These time-consuming operations would be avoided if complete floor panels were erected, without the need for concrete to be placed on site. Such solutions are often referred to as 'dry' solutions, as on-site concrete is not required.

A number of 'dry' floor solutions may be considered, described below. The overall size of the panel which can be erected is limited by the transport restrictions between the factory and the site. The panel size and type may also be limited by the capacity of the site craneage.

The offsite, factory production of the floor plate panels means that precise tolerance can be achieved. Panels are shallow, meaning that multiple panels may be transported to site in one load.

Any floor must be designed for:

- Ultimate resistance;
- Serviceability performance (deflection);
- Dynamic performance;
- Acoustic performance;
- Fire resistance.

4.1 Floor plate design with panels

In addition to the obvious requirement to carry the applied vertical actions, floor plates must behave as a diaphragm to carry loads to the core or other stability system. If the floor plate is constructed from panels without a continuous deck, individual panels must be connected along their matching edges, as shown in Figure 4.1.

The joints shown in Figure 4.1 are likely to need sealing to improve the acoustic performance of the floor.

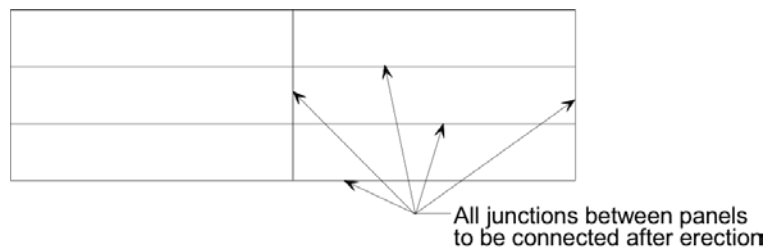

Figure 4.1 - Connections between floor panels

4.2 Composite floor panels

This is an orthodox solution, comprising conventional profiled steel sheet and concrete, acting compositely with the supporting steelwork, but with the normal construction activities moved offsite. Although many different combinations of deck profile, slab thickness, span and width are possible, the following sections offer advice on a typical solution.

An exploded view of a composite floor panel is shown in Figure 4.2.

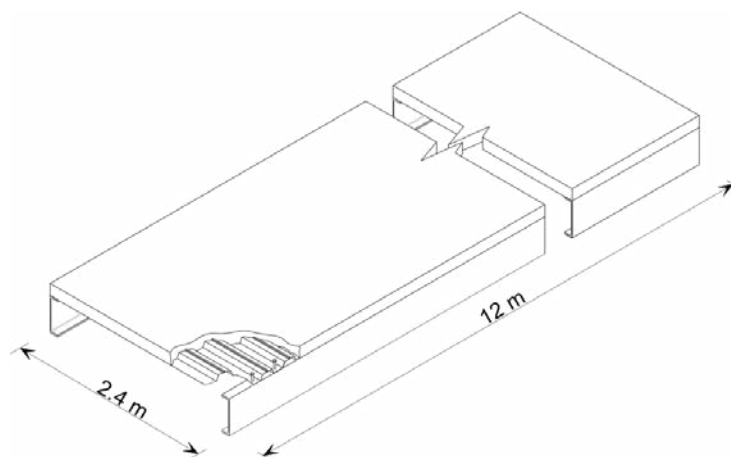

Figure 4.2 - Composite floor panel

4.2.1 Typical details

Due to transport restrictions and to meet usual planning requirements made in multiples of 300 mm, a panel of 2.4 m width is appropriate.

Three adjacent panels, each spanning 12 m, are used to give a column grid of 12 m × 7.2 m, as shown in Figure 4.3.

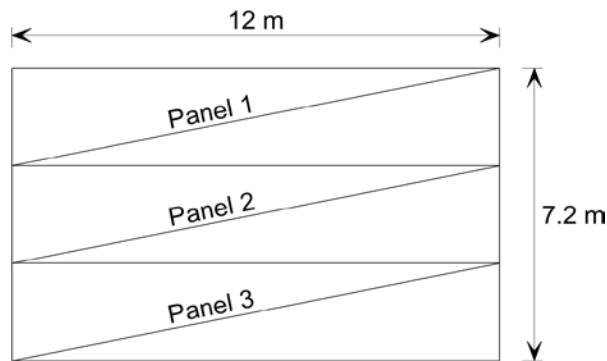

Figure 4.3 – Proposed composite floor panels

The 12 m span members are parallel flange channels (PFC), which are bolted back-to-back in the final condition after assembly of the panels, as shown in Figure 4.4. . To minimise construction depth, the panels should frame into the primary beams (which span 7.2 m in Figure 4.3), rather than be located on top of the primary beams.

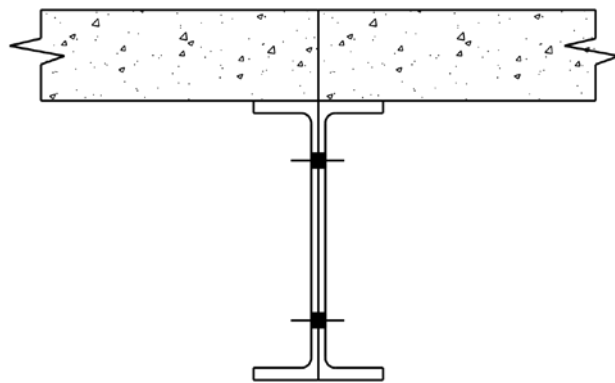

Figure 4.4 – Detail at joint between adjacent panels

4.2.2 Member design – 12 m span members

For the proposed solution, a single member may be modelled with the properties of the paired back-to-back channels, and the composite resistance verified using a spacing of steel members at 2.4 m.

To verify the resistance of the back-to-back PFC, the following design criteria and loading inputs were adopted:

- Selected member: 430 × 100 × 64 PFC, S355
- Imposed floor load: 2.5 kN/m² (From the UK NA to BS EN 1991-1-1^[20]).
- Partitions: 0.8 kN/m² (from BS EN 1991-1-1^[21]).
- Ceilings, raised floors, etc: 1.0 kN/m².
- Normal weight concrete, C30/37.
- 60 mm trapezoidal deck.
- 140 mm deep slab.
- 19 mm shear studs (one on each PFC, so two studs transversely).

Because the panels are cast offsite, the steel members are effectively propped, which means no design checks are required for the construction stage. The offsite casting means that deflections during construction are not present.

The deck between the steel members may also be propped, meaning that there is no ponding and no deflection of the deck at the construction stage.

The results of the verification are as follows:

- Applied moment: 443.2 kNm; composite resistance: 1224 kNm.
- Applied shear: 147 kN; shear resistance 1953 kN.
- Deflection of the composite section:
 - Due to permanent actions: 3.5 mm;
 - Due to variable actions: 8.9 mm.
- The deflections are well within the usual limits of 60 mm under total loads or 33 mm under variable actions alone.
- Natural frequency: 5.9 Hz

The natural frequency is only an indication of the dynamic response which must exceed 4 Hz as an initial requirement. A more appropriate verification is to consider the response factor of the system compared to the requirements for different environments (busy office, residential, etc). Comprehensive guidance on dynamic effects is given in SCI publication P354^[22].

It should be noted that the dynamic performance is critical to the design of these panels, not strength. The span may be increased to 15 m whilst maintaining a natural frequency greater than 4 Hz by increasing the panel width to 2.7 m. This is an initial assessment – the response factor should be evaluated.

The PFC is effectively an ‘edge’ member, so ‘U’ bars are required around the studs.

The overall weight of a 12 m x 2.4 m panel is approximately 9.5 tonnes.

The overall weight of a 15 m x 2.7 m panel is approximately 13 tonnes.

Lightweight concrete may be used to reduce the weight of the panels.

4.2.3 Member design – Primary members

The primary members shown in Figure 4.3 span 7.2 m (or 8.1 m with 2.7 m panel widths), with point loads at 1/3 points from the secondary steelwork. The primary members are non-composite, but restrained at the point load positions.

In the middle third of the beam, the shear force is very small, making this zone an ideal location for an elongated opening if required for the passage of services.

Appropriate plain beams are:

- For 12 m × 2.4 m panels (7.2 m span): 533 × 210 × 101, S355
- For 15 m × 2.7 m panels (8.1 m span): 610 × 229 × 125, S355

- Cellular or perforated beams may be used to facilitate the passage of services. Typical solutions are:
 - For 12 m × 2.4 m panels (7.2 m span): 533 × 210 × 109, S355, 750 mm overall depth and 500 mm diameter holes.
 - For 15 m × 2.7 m panels (8.1 m span): 610 × 229 × 179, S355, 800 mm overall depth and 500 mm diameter holes.
 - The cellular beams solutions have been designed with an elongated central opening, as shown in Figure 4.5. If the central elongated opening is stiffened as shown, the two section weights given above can be reduced to 90 kg/m and 125 kg/m respectively.

4.2.4 Fire design

The steelwork must be verified at elevated temperatures in the normal way. If an intumescent coating is applied, no special treatment at the joint between the PFC is required as the char will expand to cover any small void, if present.

Figure 4.5 – Cellular beam solution with central elongated opening

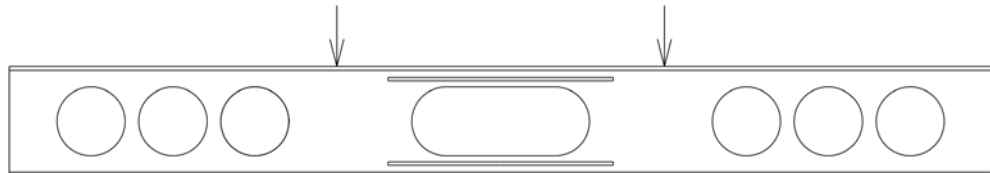

4.3 Cross laminated timber (CLT) floor panels

CLT is produced from softwood timber, made up of sections in successive layers, typically 20 mm to 45 mm thick, laid in perpendicular directions, laminated under pressure. CLT is fabricated to precise dimensions, with openings, joint details etc machined to suit.

CLT panels may be manufactured up to approximately 4 m in width and up to 18 m long (limited by transport restrictions). Thicknesses range up to 300 mm, though between 80 mm and 200 mm is common.

CLT is relatively expensive, being in the order of twice the initial cost of precast concrete floor planks. The advantages of CLT are its sustainability credentials, precise manufacture, reduced waste and light weight, which could result in savings in foundations and supporting structures. A CLT solution can be readily deconstructed and has final value as biomass if it cannot be reused.

4.3.1 Structural resistance of CLT

A design guide which may be used to establish provisional CLT thickness for span and loading conditions, in accordance with EN 1995 is available from TRADA^[23].

According to Table 5 from reference 23, a simply supported CLT panel 135 mm deep will satisfy the following conditions:

- An additional permanent action of 1.5 kN/m² (additional to the self-weight) to allow for ceilings, services and a raised floor;
- A variable action of 3.5 kN/m² (taken to be equivalent to 2.5 kN/m² imposed floor load from EN 1991-1-1 and an allowance of 1.0 kN/m² for partitions);
- A deflection limit of span/350 under the variable actions.

A 135 mm deep CLT panel would therefore be appropriate for a floor panel either 2.4 m or 2.7 m wide, and a length to suit the column grid.

4.3.2 Supporting steelwork

CLT may be simply bolted or screwed to the top of a parallel flange channel (PFC), as indicated in Figure 4.6.

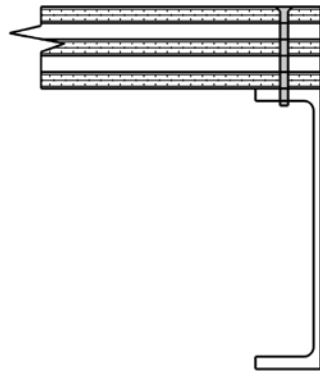

Figure 4.6 – CLT fixed to the top flange of a parallel flange channel

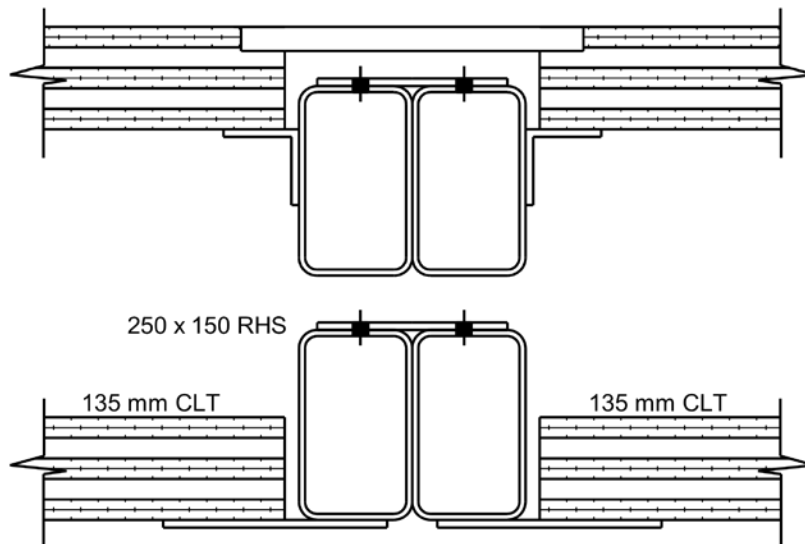

Figure 4.7 – CLT supported by rectangular hollow sections

If a shallow floor solution is required, a rectangular hollow section may be used, as shown in Figure 4.7. Adjacent panels need connecting to form a diaphragm. So-called ‘blind’ fixings may be used to connect into hollow sections from one side only.

In both options, a primary beam must span between columns to support the panels.

4.3.3 Preliminary sizing of panel steelwork

Assuming a 6 m × 6 m grid, and panels 2 m wide, the primary steelwork shown in Figure 4.6 could be a 200 × 90 × 30 PFC.

The design data is as follows:

- 200 × 90 × 30 PFC, S355.
- Applied moment: 36.8 kNm; moment resistance 100 kNm
- Deflection under variable actions: 11.2 mm; allowable 16.7 mm
- Dynamic frequency 6.4 Hz.
- With the same panel size, the primary steelwork shown in Figure 4.7 could be a 200 × 100 × 8 RHS.
- The design data is as follows:
 - Applied moment: 36.8 kNm; moment resistance 97 kNm
 - Deflection under variable actions: 12.6 mm, allowable 16.7 mm
 - Dynamic frequency 6.0 Hz.

In both cases the response factor should be determined in accordance with SCI publication P354^[22].

The weight of a 2 m × 6 m panel with 135 mm CLT is approximately 1.3 tonnes.

4.3.4 Primary beam preliminary size

The primary beam spans 6 m, with point loads and restraints at 1/3 span locations.

A plain 356 × 171 × 45 UB would be satisfactory, or a deeper perforated beam if it is desired to pass services through the primary beams. To minimise construction depth, the PFC or RHS members would frame into the supporting steelwork, rather than sit on top of the beam.

4.3.5 Fire performance

CLT panels can be produced with a fire resistance period of up to 90 minutes^[24]. The performance depends on the number and thickness of the plies and the adhesive used in the lamination process. Specialist advice from the manufacturer should be obtained. CLT may be protected by one or more layers of fire resistant plasterboard.

The steel members will require protection in the same way as more orthodox construction.

4.3.6 Acoustic performance

In similar fashion to other construction solutions, attention to detail is required at the joints between floors and walls. Acoustic performance through the floor can be improved by the use of raised floors, or with a double layer of plasterboard supported on resilient bars. Acoustic details at floor to wall junctions – necessary to avoid flanking sound transmission – are presented in SCI Publication P372^[40].

4.4 Light gauge floor cassettes

The term ‘light gauge’ steelwork refers to cold rolled steel sections, usually ‘C’ sections, formed from galvanized steel typically 1 – 3 mm thick. A wide range of profiles are available from a variety of manufacturers.

The use of cassettes, formed with light gauge steel floor joists with a chipboard or orientated strand board (OSB) floor is a variation of existing technology used in light steel modular construction. Light gauge steel joists are often used back-to-back, and can readily accommodate spans of 6 m. Acoustic performance is enhanced by mineral wool quilt within the cassette. Fire protection is provided by layers of fire resisting boards. A typical cross section is shown in Figure 4.8.

Figure 4.8 – Section through a light gauge floor cassette

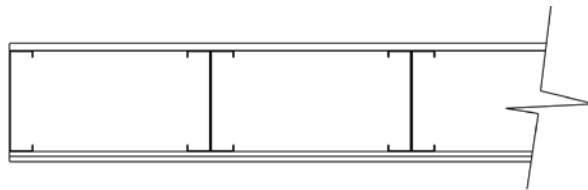

Figure 4.9 shows a floor cassette being erected.

As the name suggests, the solution is lightweight, with a typical weight of only 1 tonne for a panel 3 m × 6 m.

Figure 4.9 – Erection of a floor cassette



4.4.1 Typical details

For residential imposed loading, and 6 m spans, the steel ‘C’ sections are typically 250 – 300 mm deep, 2.5 mm thick.

The ‘C’ sections may be singly spaced, or in back-to-back pairs. Connections between adjacent panels (to provide a floor diaphragm) may be made by bolting between the panels, leaving the plasterboard off the soffit in the joint zone.

Continuity of the boarding is important in reducing dynamic effects (it enables sharing of load between joists and mobilisation of sufficient mass), so as shown in Figure 4.10, the spacing of the end 'bay' of the floor cassettes may be reduced to offset the effect of the joint in the flooring.

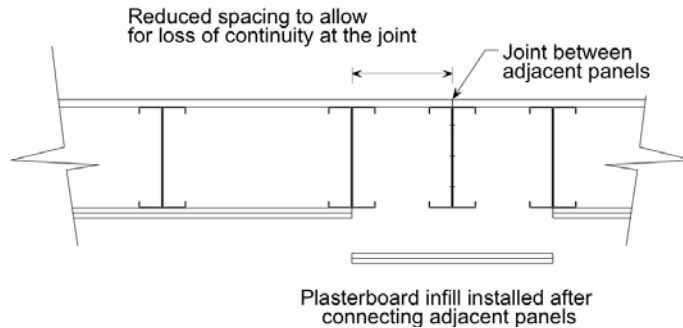

Figure 4.10 – Possible joint detail between light gauge panels

On the lines of the columns, a member will be required to carry tying forces. Typically, this may be a Tee section located between adjacent panels, as shown in Figure 4.11.

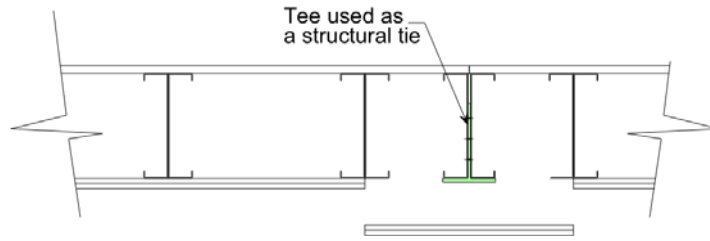

Figure 4.11 – Possible joint detail between light gauge panels

The 'C' sections may be perforated to facilitate the passage of services, as shown in Figure 4.12 (image taken from the underside of a floor panel with no plasterboard). Protection of the services as they pass through the 'C' section is usually provided.



Figure 4.12 – Services passing through light gauge floor steelwork.

The presence of large holes may have a considerable impact on the structural resistance of the section, so must be verified. In Figure 4.13, the oval openings for services have been stiffened by forming a return around the edge of the opening.



Figure 4.13 – Stiffened service holes in light gauge floor steelwork

The flooring membrane is typically 22 mm chipboard or oriented strand board (OSB).

4.4.2 Supporting steelwork

In a similar way to a CLT panel, three light gauge floor cassettes would be used side-by-side, to create a column grid of 6 m × 6 m. Primary steelwork supports are needed to span 6 m, to support the floor cassettes.

A 305 × 165 × 40 UB, in S355 (or similar performance section) would be a typical primary steelwork member. A deeper section with web perforations may be used if it is desirable to pass services through the primary beam.

The connections between the floor cassettes and the primary steelwork depend on the details developed by the manufacturer, but the top of the cassette steelwork and supporting steelwork could be located at the same level, providing a shallow solution.

4.4.3 Serviceability and dynamic performance

For residential construction, the National House-Building Council (NHBC) specifies requirements for static and dynamic performance, based on checks of deflection. Full details of the requirements, together with minimum sizing requirements (second moment of area) which satisfy the requirements are given in SCI publication P402^[25].

4.4.4 Fire performance

Two layers of fire-resistant plasterboard and mineral wool between the ‘C’ sections are generally sufficient to provide a 90 minute fire resistance period.

4.4.5 Acoustic performance

To improve acoustic performance, proprietary sound insulation matting is often fixed between the steel joists (as can be seen in Figure 4.12). In addition, a final flooring layer may be laid on top of the floor cassette, with proprietary battens, dense mineral wool of a resilient layer below the floor finish. Further details are provided in SCI publications P372^[10] and P402^[25].

4.5 Façades and roof panels

Offsite prefabrication of façades is not a new development, although the physical size of the units proposed in Section 4.5.1 makes the solution innovative.

In the UK, roofs of industrial structures are generally secondary steelwork (purlins), spanning between the primary steelwork, supporting either built up cladding or preformed composite sandwich panels of metal skin and a core of insulation. In the UK context, roof construction for industrial buildings is relatively lightweight.

In other countries, where imposed loads are higher due to snow loading, more substantial roof construction is common. In these circumstances, prefabricated panels incorporating the structural elements have been successfully used. Further comments on the application of these systems in the UK are given in Section 4.5.4.

In multi-storey office and residential construction, the roof is often of similar construction to the floors. The floor solutions previously presented could be replicated at roof level, or the alternative lightweight solutions discussed in this section could be used where loading conditions permit.

4.5.1 Façade panels

Prefabricated unitised façade panels, including the cladding, glazing and some services have been successfully used in the UK. Figure 4.14 shows an example of a panel with brickwork and glazing.

Similarly, infill walling (between storeys), supported by light gauge steelwork, is a familiar technology. Infill walling does not carry vertical load.



Figure 4.14 –
Prefabricated
façade panel,
University College
London Hospital

Figure 4.15 shows a typical light gauge infill. Infill wall panels may be prefabricated, with insulation and weatherproofing applied offsite. The primary advantage of prefabricated panels is the earlier dry envelope (allowing earlier access for following trades) and the shorter overall construction programme. A 25% reduction in overall construction programme is possible^[26].

Figure 4.15 – Light steel infill wall used in a multi-storey steel-framed residential building (Image courtesy of Metek UK)



Prefabricated wall panels are formed with a stiff structural core, insulation and a vapour barrier on the external face. Panels may have internal finishes already fixed, and have openings for windows provided.

Prefabricated panels are dimensionally precise and are engineered to provide acoustic, thermal and fire performance.

4.5.2 Continuous walling

Continuous walling is a variant of infill walling. Continuous walling systems generally involve vertical light gauge steel 'C' sections fixed to the primary frame as shown in Figure 4.16, and cladding attached to this supporting framework.

Figure 4.16 – Bracket connection for continuous walling incorporating slotted connections (Image courtesy of Kingspan Profiles & Sections)



4.5.3 Panelised continuous walling

A development of continuous walling is to use vertical panels extending over three or four storeys, erected as prefabricated semi-finished components. The primary advantage of this type of system is the significantly reduced programme to provide an enclosed weatherproof envelope.

Panels are typically 2.4 m or 3 m wide (due to transport restrictions) and may be three or four storeys in height. The panels are supported at the base, with simple bracket connections at the intermediate floor levels to transfer the lateral load.

The structural core of the panel may be light gauge steelwork, or cross laminated timber (CLT). The principles and design requirements are the same in both forms of panel. It is not currently possible to use CLT in wall panels over 18 m from the ground level, due to fire regulations which prohibit the use of combustible materials in such situations.

Panels must span structurally between floors, being designed for wind loading. The temporary case when the panels are lifted from horizontal to vertical may be an important design case, particularly if the panels are complete with cladding.

The vertical joint between panels may be fitted with a bespoke gasket system to provide an effective waterproof and weatherproof barrier. Alternatively, the completed façade may be clad in a rain screen system.

SCI Publication P402^[25] provides details of the structural, serviceability, fire, thermal and acoustic performance of light gauge steel façade systems.

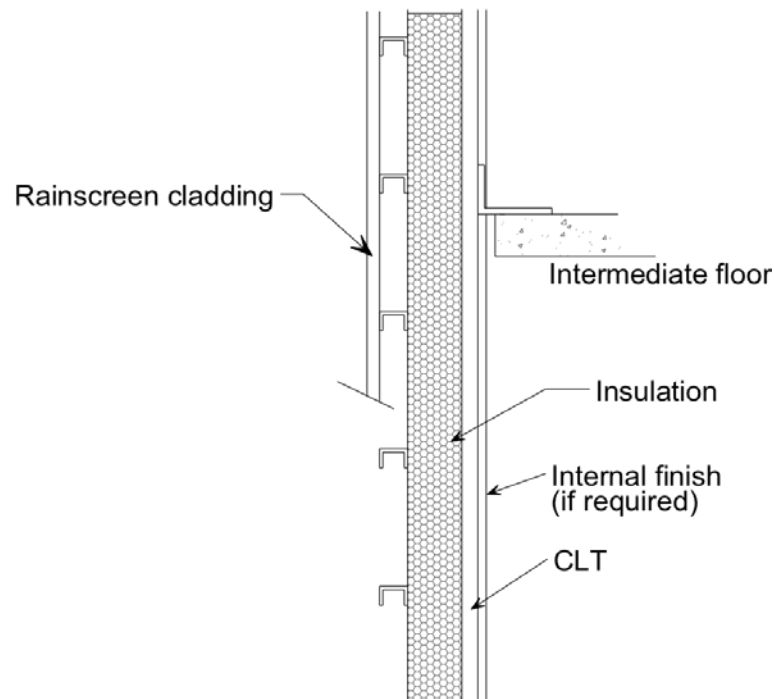

Figure 4.17
– Continuous
walling panel with
structural core
from CLT

4.5.4 Roof panels

Although prefabricated roof panels could be manufactured in the same way as façade panels, as described in Section 4.5.3, certain aspects of UK practice mean the use of secondary steelwork is likely to be preferred.

UK practice is to use Universal Beams (UB) as roof supports for industrial structures. Under uplift conditions, the bottom flange of the UB is restrained by diagonal members from the flange to the secondary steelwork, as shown in Figure 4.18. If a prefabricated panel is used, the restraint details will be more complex and additional bracing systems may be required. In countries where prefabricated panels are more common, roof steelwork tends to be hollow sections, which need no inner flange restraint.



Figure 4.18 – Typical roof beam restraint details for secondary steelwork

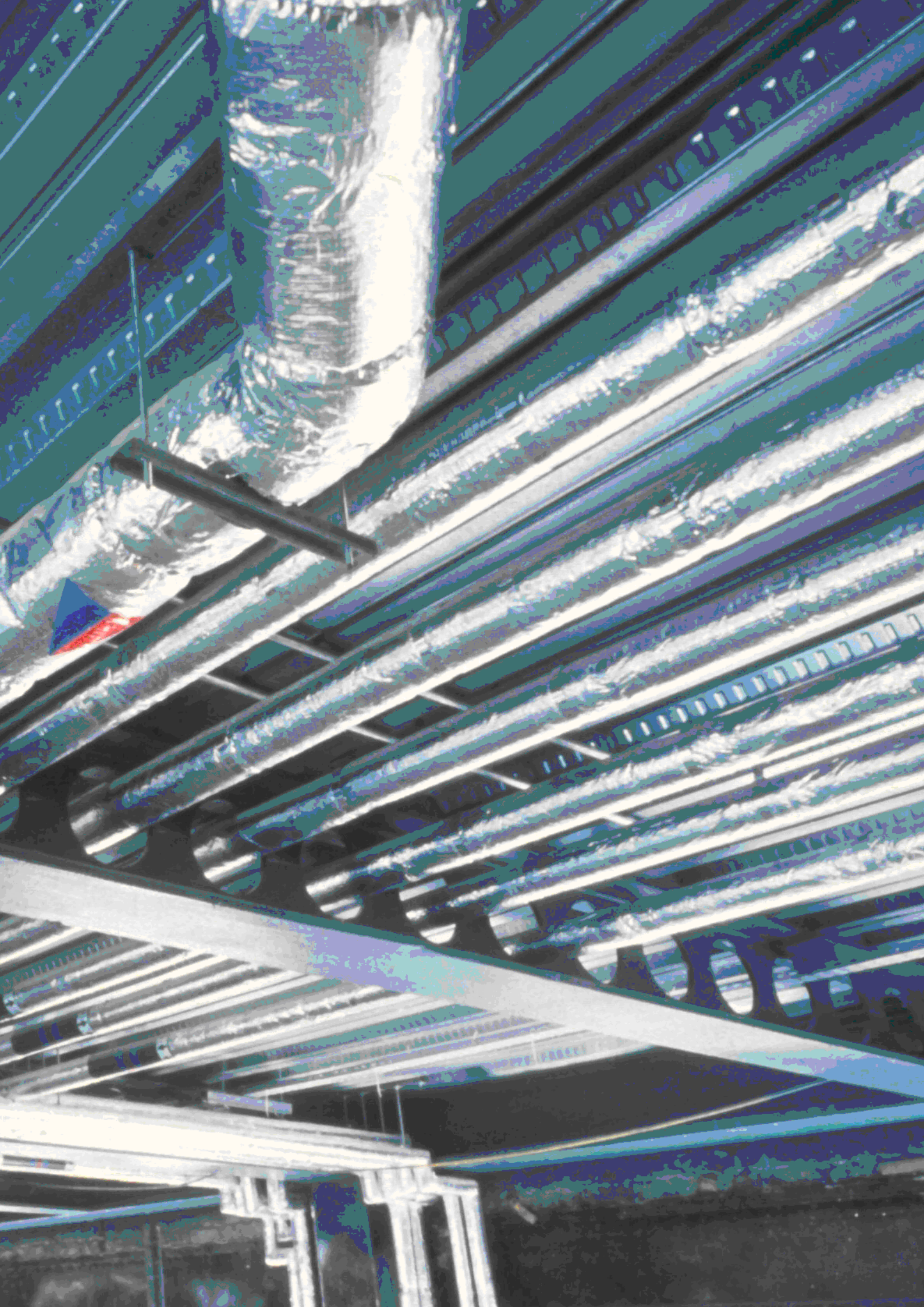

INTEGRATED SERVICES

It is clear that opportunities exist to integrate services with all the solutions described in this guide. The cost of the services and their installation is a significant cost and significant contribution to the overall programme.

Currently (2020), the main barriers to integration of services are:

- Programme: Often, the M&E design is executed by the contractor and therefore commences relatively late in the programme. By this stage, the structural design is mature and opportunities for integration are limited.
- Design: Detailed M&E design is executed by the M&E contractor, so different solutions must be accommodated in the scheme design.
- Price: The services contractor may offer a lower price for an orthodox solution, as no assembly facility is needed. Site installation of individual services may be cheaper than handling and installing prefabricated service modules.

Some examples of successful services integration can be identified, primarily when minimal disruption and a short site programme is essential (such as construction of hospital wards), or when space saving is essential.

If the benefits of prefabrication and preassembly of services are to be realised, the key principles are:

- An early decision that the services will be prefabricated.
- A design which is specific to offsite manufacture.
- An overall programme that delivers which information.

Detailed advice, illustrated with case studies is presented in Reference 27.



nationwide

nationwide

REFERENCES

- [1] *Offsite modular steelwork: Advice to clients (P431)*
SCI and BCSA, 2019
- [2] *Transforming Infrastructure Performance Crown, 2017*
- [3] *Industrial Strategy: Construction Sector Deal Crown, 2018*
- [4] <https://www.aisc.org/modernsteel/news/2019/august/rainier-square-tower-tops-out-at-850-ft-in-under-10-months/#.XbMMYxYayo>
- [5] <https://archpaper.com/2018/01/seattle-second-tallest-tower-no-rebar/>
- [6] <https://www.aisc.org/why-steel/innovative-systems/SpeedCore/#55714>
- [7] Aggelopoulos E. S, Burgan B. A.
Design of steel concrete composite (SC) structures (P414)
SCI, 2019
- [8] Joints in steel construction
Simple Joints to Eurocode 3 (P358)
SCI and BCSA, 2014
- [9] Cosgrove T, King C, Yandzio E
Design of building cores using Corefast
(unpublished, available in draft from SCI)
- [10] Way A. G. J, Couchman, G. H.
Acoustic detailing for steel construction (P372)
SCI, 2008
- [11] *NCCI: Design of reinforced concrete filled, hot-finished structural steel hollow sections in fire (PNO06a=GB)*
Steelconstruction.info
- [12] *AD 376: Fire design of concrete-filled hollow steel columns to Eurocode 4*
New Steel Construction, July 2013
- [13] FIRESOFT
Available via <http://software.tatasteeltubes.com/>
- [14] BS EN 1994-1-1: 2004
Eurocode 4 – Design of composite steel and concrete structures – Part 1-1: General rules and rules for buildings
BSI, 2005

- [15] BS EN 1994-1-2: 2005 + A1:2014
Eurocode 4 – Design of composite steel and concrete structures – Part 1-2: General rules – structural fire design
 BSI, 2014
- [16] Davison B, Owens G. W (Editors)
Steel Designers’ Manual
 Wiley-Blackwell, 2012
- [17] BS EN 1993-1-2:2005 + Corrigenda Nos 1 and 2
Eurocode 3: Design of steel structures – Part 1-2: General rules – structural fire design
 BSI, 2006
- [18] Dujmovic D, Androic B, Tonis D, Lukacevic I
Composite columns made of concrete-filled hollow steel sections with embedded steel cores
 Gradevinar, Volume 69, Issue 4, 2017
- [19] AD 292: *The use of discontinuous columns and shallow deck composite slabs on floor beams*
 New Steel Construction, October 2005
- [20] NA to BS EN 1991-1-1:2002
UK National Annex to Eurocode 1: Actions on structures – Part 1-1: General actions – Densities, self-weight, imposed loads for buildings
 BSI, 2005
- [21] BS EN 1991-1-1:2002, including corrigenda Dec 2004 and March 2009
Eurocode 1: Actions on structures – Part 1-1: General actions – Densities, self-weight, imposed loads for buildings
 BSI, 2010
- [22] Smith, A. L, Hicks S. J, Devine, P. J.
Design of floors for vibration: A new approach (Revised edition) (P354)
 SCI, 2009
- [23] *Guidance document 10 (DG10) Cross-laminated Timber (Eurocode 5) Design Guide for project feasibility*
 Trada Technology, 2009
- [24] *Crosslam timber / CLT – fire resistance and rating*
<http://greenspec.co.uk/building-design/crosslam-timber-fire-resistance-and-rating/>
- [25] Yandzio, E. Lawson, R. M. Way, A. G. J.
Light steel framing in residential construction (P402)
 SCI, 2015
- [26] KingBuild system
<https://www.kingspan.com/gb/en-gb/products/structural-steel-solutions/steel-building-solutions/kingbuild-system>
- [27] Wilson D. G, Smith M.H, Deal J.
Prefabrication and preassembly
 The Building Services Research and Information Association (BSRIA), 1998

CREDITS



34 Fig 4.15
Metek UK



34 Fig 4.15
Kingspan Profiles and Sections

OFFSITE MODULAR STEELWORK

DESIGN ADVICE

Increased offsite integration of structural steelwork with complementary building components and building services offers the opportunity of shorter site programmes, higher quality, reduced waste and a safer construction environment.

This document presents the results of a collaborative project funded by Innovate UK to examine technical solutions that may be used to deliver benefits in multi-storey construction. Proposals for standardised solutions are presented, which may be developed and refined for specific applications.

A companion guide has been prepared to alert clients to the benefits of increasing offsite integration.

Complementary titles

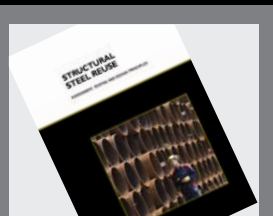

P427 | Structural steel reuse

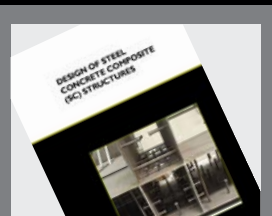

P414 | Design of steel composite (SC) structures

SCI Ref: P430

SCI

Silwood Park, Ascot, Berkshire. SL5 7QN UK

T: +44 (0)1344 636525

F: +44 (0)1344 636570

E: reception@steel-sci.com

www.steel-sci.com



9 781859 422441 >